

- A **branch** represents a single element such as a voltage source or a resistor
- A **node** is the point of connection between two or more branches
- A **loop** is any closed path in a circuit i.e., a loop is a closed path formed by starting at a node, passing through a set of nodes, and returning to the starting node without passing through any node more than once.
- A network with b branches, n nodes, and l independent loops will satisfy the fundamental theorem of network topology:

$$b = l + n - 1$$

In Fig:
Branches?
Nodes?
Independent loops?

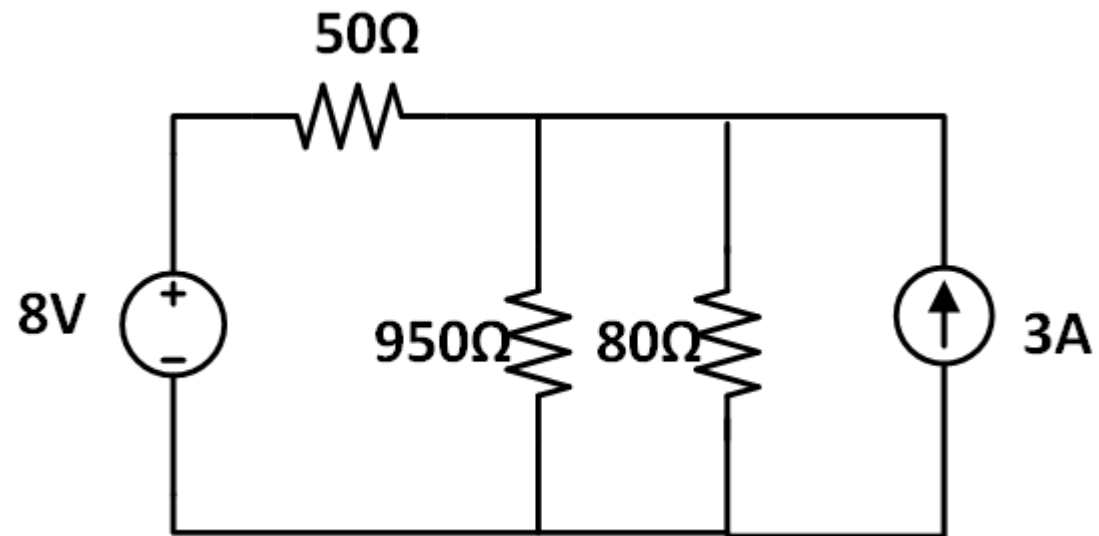

Kirchhoff's Current Law (KCL)

- Kirchhoff's current law (KCL) states that the algebraic sum of currents entering a node (or a closed boundary) is zero.

$$\sum_{n=1}^N i_n = 0$$

- The sum of the currents entering a node is equal to the sum of the currents leaving the node.
- By this law, currents entering a node may be regarded as positive, while currents leaving the node may be taken as negative or vice versa.

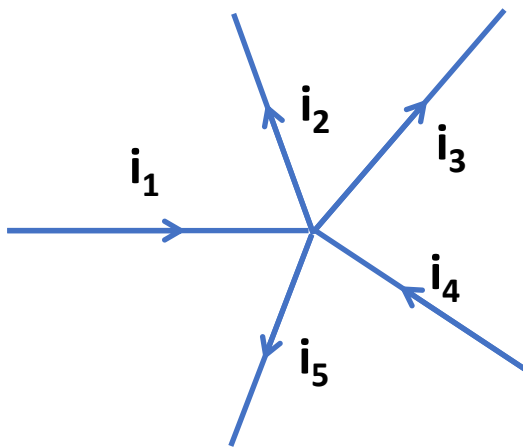

$$i_1 + (-i_2) + (-i_3) + i_4 + (-i_5) = 0$$

$$i_1 + i_4 = i_2 + i_3 + i_5$$

Kirchhoff's Voltage Law (KVL)

- Kirchhoff's voltage law (KVL) states that the algebraic sum of all voltages around a closed path (or loop) is zero.

$$\sum_{m=1}^M v_m = 0$$

- In any closed loop, sum of voltage drops is equal to the sum of voltage rises.
- The sign on each voltage depends on the polarity of the terminal encountered first. The loop may be considered either clockwise or counterclockwise. Suppose, we start with the voltage source v_1 and go clockwise around the loop; then voltages would be $-v_1$, $+v_2$, $+v_3$, $-v_4$, and $+v_5$, in that order. For example, as we reach branch 3, the positive terminal is met first; hence we have $+v_3$. For branch 4, we reach the negative terminal first; hence, $-v_4$.

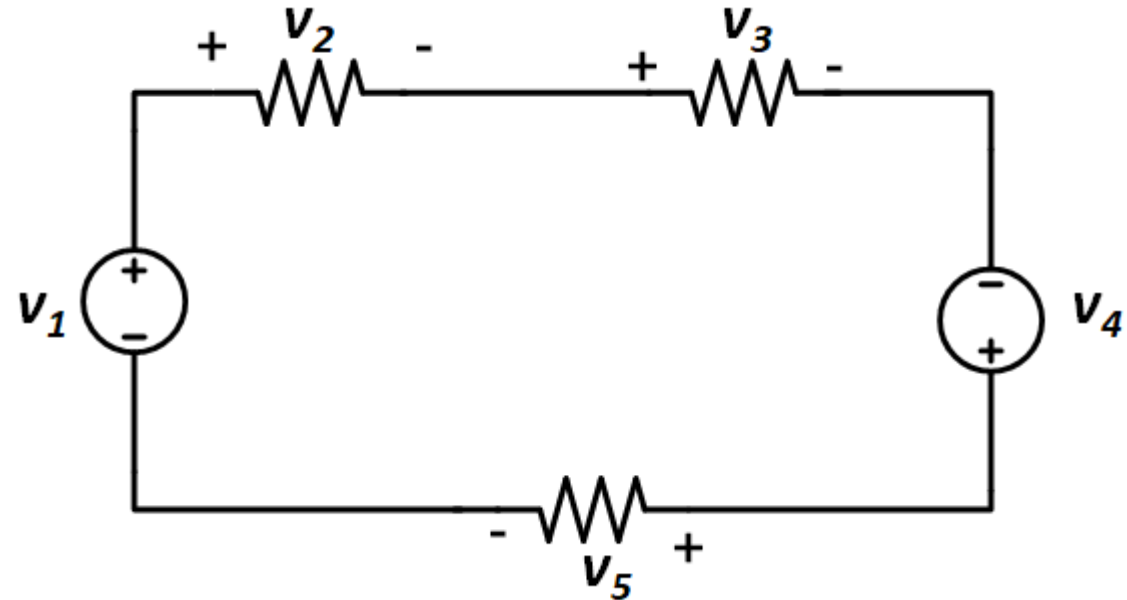

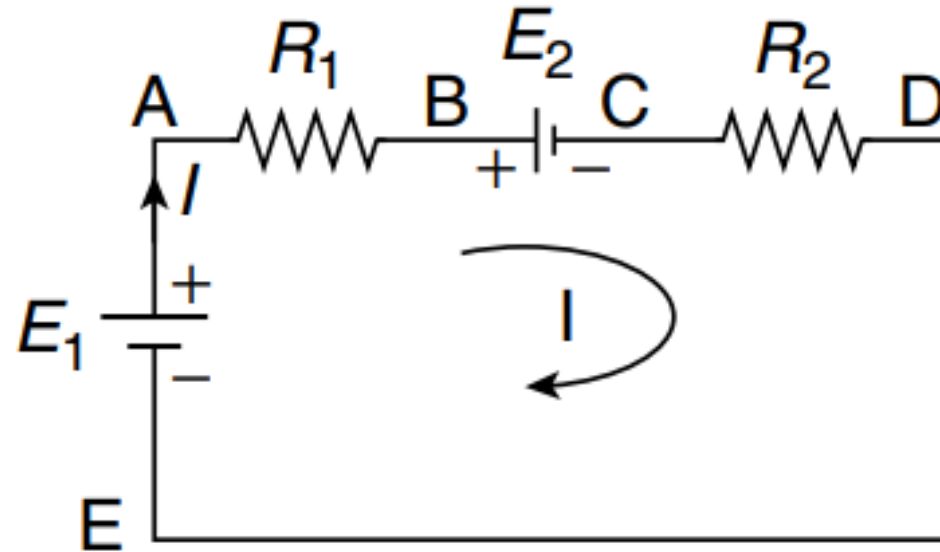

By applying KVL in the closed loop ABCDEA, all the branch voltages are equated to zero.

Practice Problems

Q: Calculate the current flowing through all the branches in the following circuits using current division.

