

Norton's Theorem

- Norton's theorem states that a linear two-terminal circuit can be replaced by an equivalent circuit consisting of a current source I_N in parallel with a resistor R_N , where I_N is the short-circuit current through the terminals and R_N is the input or equivalent resistance at the terminals when the independent sources are turned off.

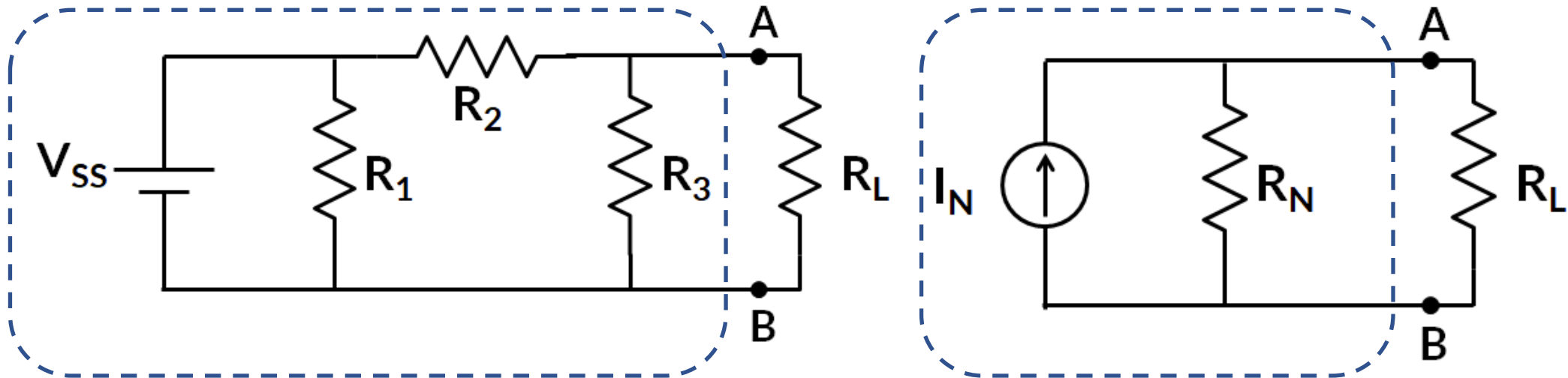

To Find R_N

1. Remove that portion of the network across which the Norton's equivalent circuit needs to be found.
2. Load resistor R_L is temporarily removed from the network.
3. Mark the terminals of the remaining two-terminal network (say **A** and **B**).
4. Identify all voltage and current sources and retain their internal resistances if any.
5. Replace the voltage sources by short circuits
6. Replace the current sources by open circuits
7. Find the resistance between terminal **A** and **B**

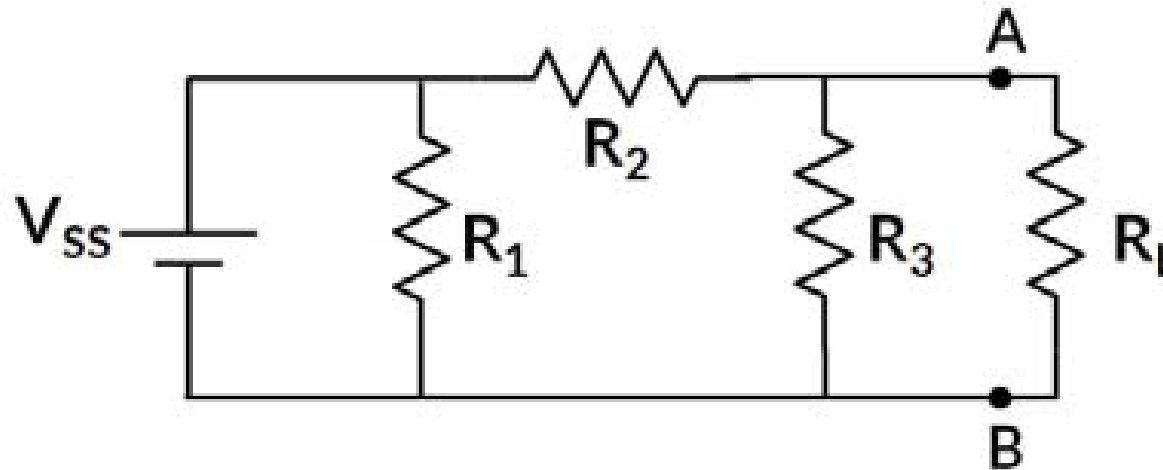

The process of finding R_{TH} and R_N is exactly same. Hence $R_{TH} = R_N$

To Find I_N

1. In the original circuit, short the load resistor (R_L) connected between the marked terminals (**A** and **B**).
2. Find the short-circuit current (I_N) through the marked terminals (**A** and **B**).
3. I_N is called as Norton's current source.
4. Draw the Norton's equivalent circuit by keeping I_N , R_N and the load resistor (R_L) in parallel.

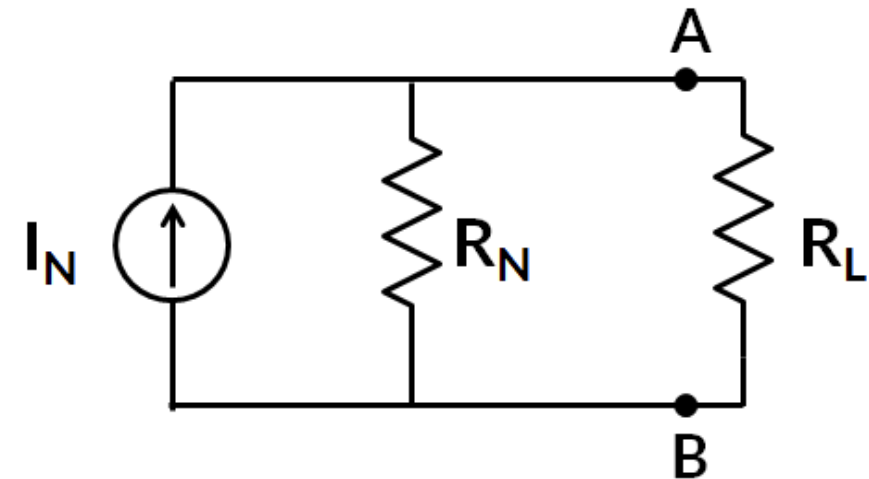
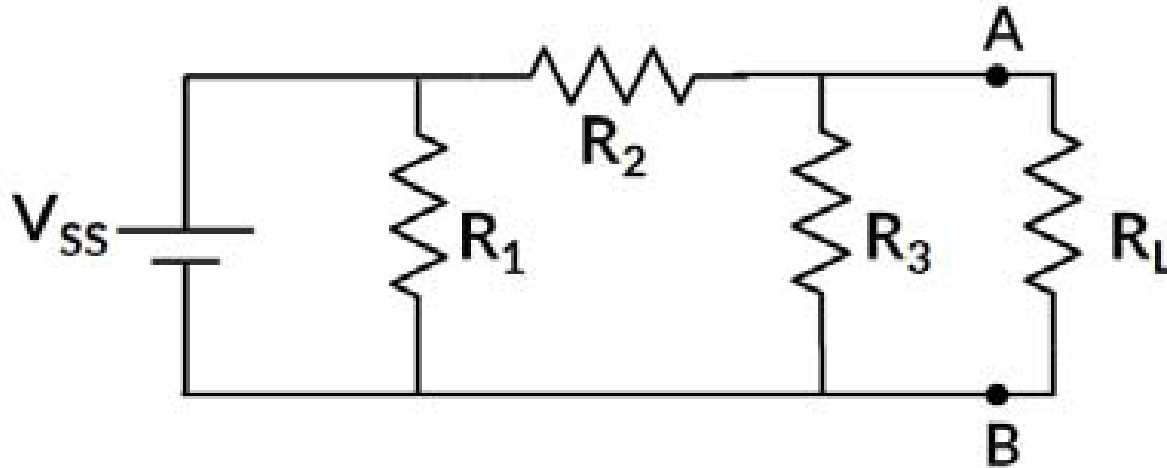

Identify that V_{TH} , R_{TH} and I_N , R_N form a source transformation for the same equivalent circuit with $R_{TH} = R_N$

Problem1 Using Norton's theorem, find the voltage across and current through the $12\ \Omega$ resistor.

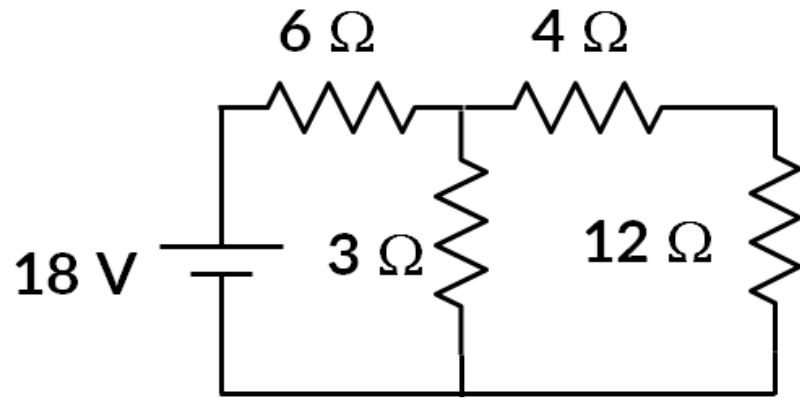

To Find R_N

Step 1: Find that portion of the network across which the Norton equivalent circuit needs to be found. (Identifying the load as $12\ \Omega$ resistor, marking the nodes **A** and **B**)

Step 2: Load resistor R_L is temporarily removed from the network.

Step 3: Mark the terminals of the remaining two-terminal network (say **A** and **B**).

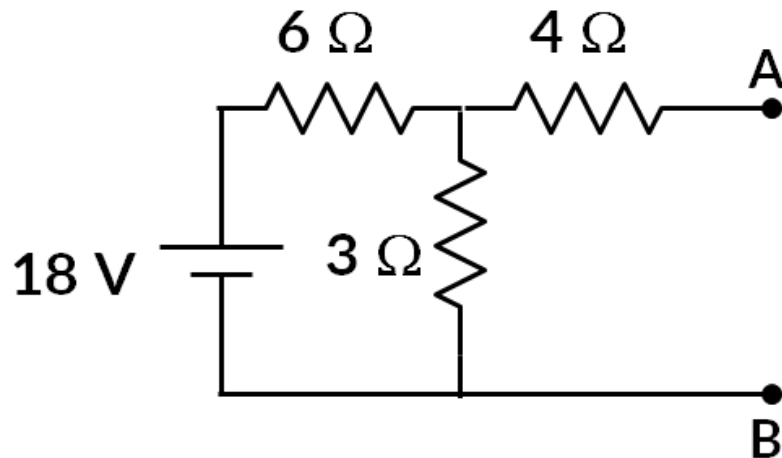

Step 4: Identify all voltage and current sources and retain their internal resistances if any. There is only one voltage source 18 V, with zero internal resistance

Step 5: Replace the voltage sources are replaced by short circuits (as there is only one voltage source in this example, replace it with a short circuit)

Step 6: Replace the current sources by open circuits (as there are no current sources, we won't act on this step)

Step 7: Find the resistance between terminal **A** and **B**

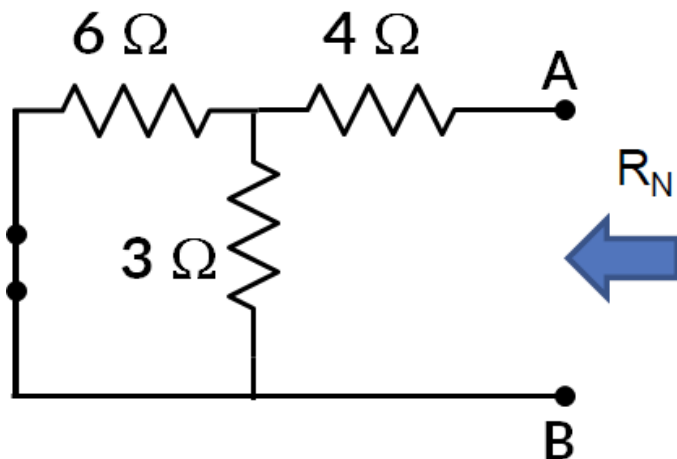

$$R_N = 4 + (6 \parallel 3) = 6 \Omega$$

To Find I_N

Step 1: In the original circuit, short the load resistor (R_L) connected between the marked terminals (**A** and **B**).

Step 2: Find the short-circuit current (I_N) between the marked terminals (**A** and **B**). I_{AB} is Norton's current, denoted by symbol I_N .

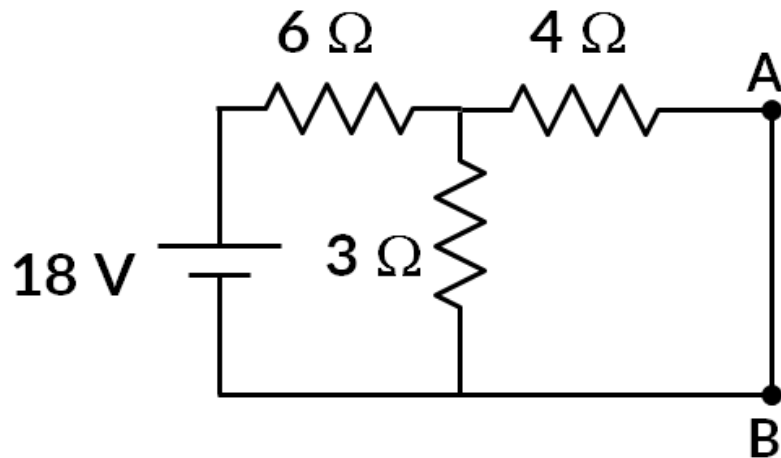

1. Current through terminals A and B is given by the current through 4 Ω resistance.
2. Total current in the circuit is

$$I = \frac{V}{R} = \frac{18}{6\Omega + (3\Omega \parallel 4\Omega)} = \frac{18}{6\Omega + \frac{12}{7}\Omega} = \frac{7}{3} \text{ A}$$

3. Current through 4 Ω is found by using current division formula.

$$I_{AB} = \frac{7}{3} \frac{3}{3+4} = 1 \text{ A} = I_N$$

Step 3: Draw the Norton's equivalent circuit by keeping I_N , R_N and the load resistor (R_L) in parallel

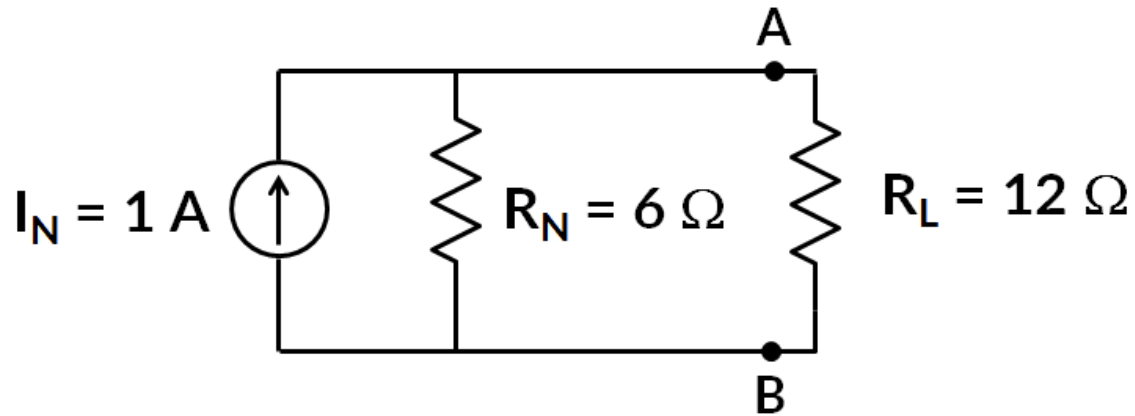

1. Use current divider formula Current through the $12\ \Omega$ resistor.

$$I_{12\Omega} = 1\text{ A} \frac{6\ \Omega}{6\ \Omega + 12\ \Omega} = 0.33\text{ A}$$

2. Voltage across $12\ \Omega$ resistor.

$$V_{12\Omega} = 0.33\text{ A} \times 12\ \Omega = 4\text{ V}$$

Problem2 Using Norton's theorem, find the voltage across and current through the 7 k Ω resistor.

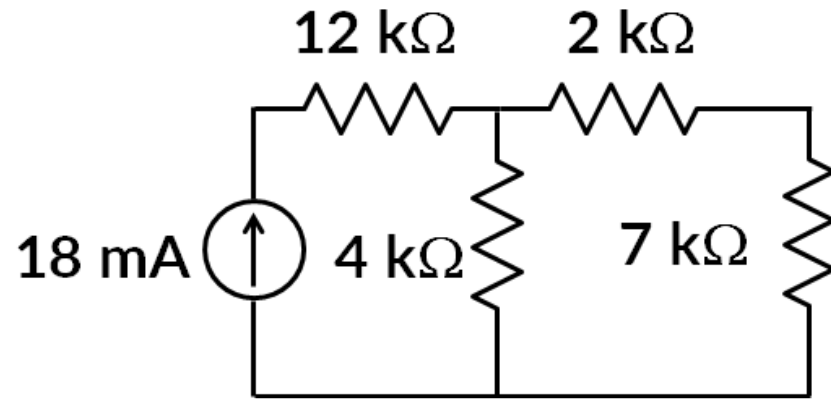

To Find R_N

Step 1: Find that portion of the network across which the Norton equivalent circuit needs to be found. (Identifying the load as 7 k Ω resistor, marking the nodes **A** and **B**)

Step 2: Load resistor R_L is temporarily removed from the network.

Step 3: Mark the terminals of the remaining two-terminal network (say **A** and **B**).

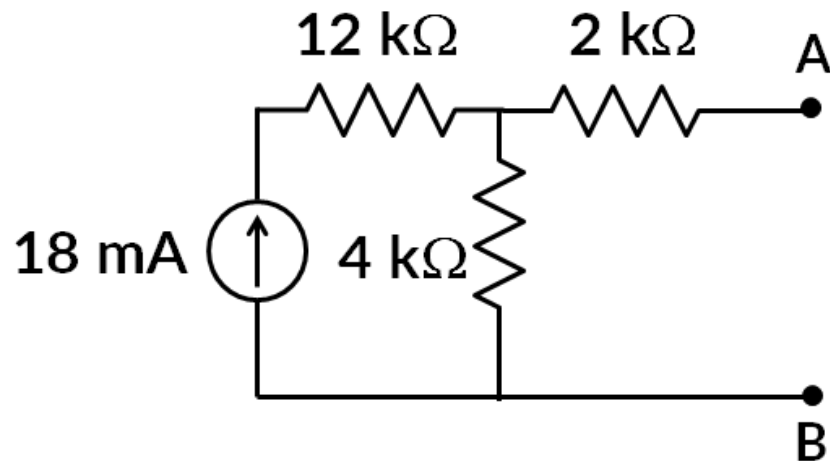

Step 4: Identify all voltage and current sources and retain their internal resistances if any. There is only one voltage source 18 V, with zero internal resistance

Step 5: Replace the voltage sources are replaced by short circuits (as there is only one voltage source in this example, replace it with a short circuit)

Step 6: Replace the current sources by open circuits (as there are no current sources, we won't act on this step)

Step 7: Find the resistance between terminal **A** and **B**

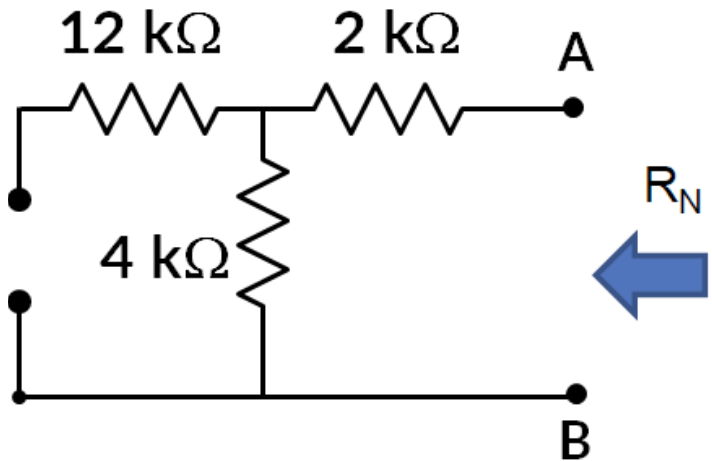

$$R_N = 2 + 4 = 6 \text{ k}\Omega$$

To Find I_N

Step 1: In the original circuit, short the load resistor (R_L) connected between the marked terminals (**A** and **B**).

Step 2: Find the short-circuit current (I_N) between the marked terminals (**A** and **B**). I_{AB} is Norton's current, denoted by symbol I_N .

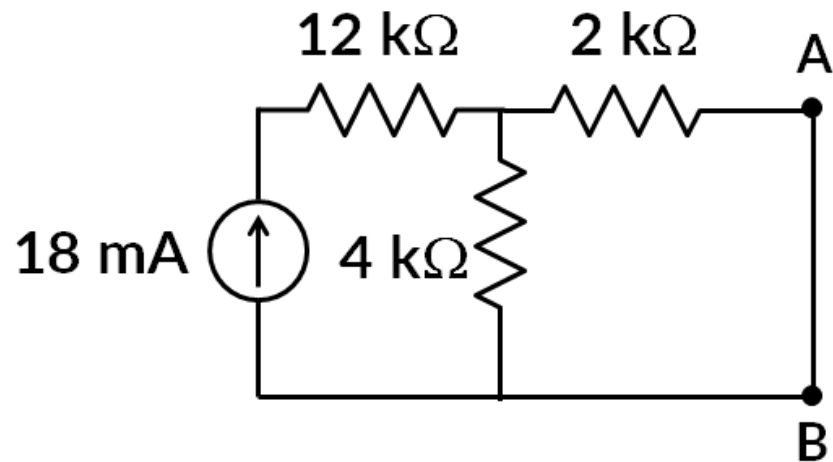

1. Current through 2 kΩ resistance passes through the nodes **A** and **B**
2. This is due to the fact that current entering into 2 kΩ should leave (KCL) and there are no other sources.
3. Current through 2 kΩ is found by using current division formula

$$I_{2k\Omega} = I \frac{R_2}{R_1 + R_2} = 18 \text{ mA} \frac{4 \text{ k}\Omega}{2 \text{ k}\Omega + 4 \text{ k}\Omega} = 12 \text{ mA}$$

Step 3: Draw the Norton's equivalent circuit by keeping I_N , R_N and the load resistor (R_L) in parallel

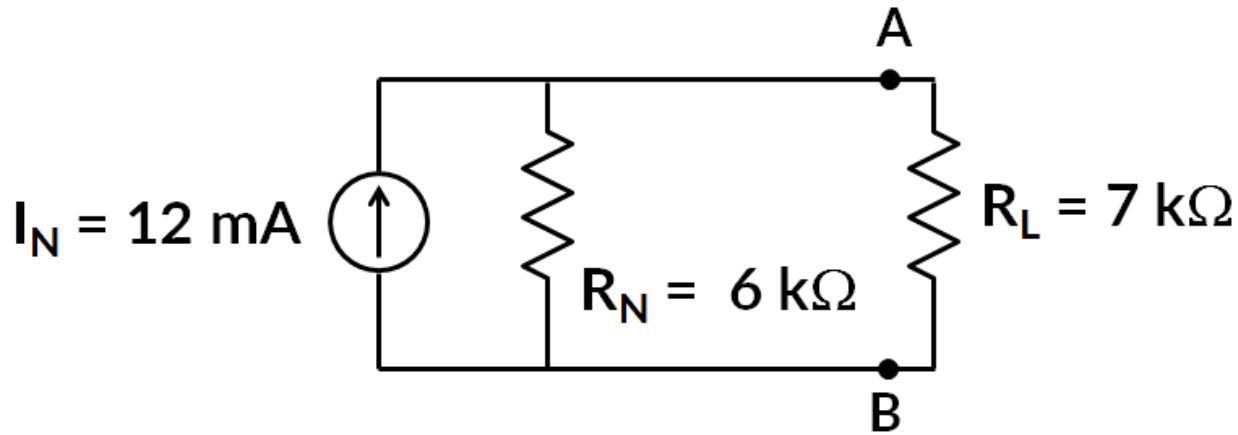

1. Use current divider formula to get Current through the $7 \text{ k}\Omega$ resistor.

$$I_{7 \text{ k}\Omega} = I \frac{R_2}{R_1 + R_2} = 12 \frac{6 \text{ k}\Omega}{6 \text{ k}\Omega + 7 \text{ k}\Omega} = 5.54 \text{ mA}$$

2. Voltage across the $7 \text{ k}\Omega$ resistor is given by (what was asked in the question)

$$V_{7 \text{ k}\Omega} = 5.54 \text{ mA} \times 7 \text{ k}\Omega = \frac{29.1 \text{ V}}{7 \text{ k}\Omega} = 38.77 \text{ V}$$

- Superposition theorem states that the current through, or voltage across, an element in a linear bilateral network is equal to the algebraic sum of the currents or voltages produced independently by each source.
- The superposition theorem is useful in finding solutions to the networks with two or more sources that are not in series or parallel.
- The superposition principle states that the voltage across (or the current through) an element in a linear circuit is the algebraic sum of the voltages across (or currents through) that element due to each independent source acting alone.
- We consider one independent source at a time while all other independent sources are turned off. This implies that we replace every voltage source by 0 V (or a short circuit), and every current source by 0 A (or an open circuit). This way we obtain a simpler and more manageable circuit.

Steps Required to Apply the Superposition Principle

1. Turn off all independent sources except one. Find the output (voltage or current) due to the active source.
2. Repeat step 1 for each of the other independent sources.
3. Find the total output by adding algebraically all of the results found in steps 1 & 2 above.

Problem1 Using Superposition Theorem find the current through the 0.5 kΩ resistor.

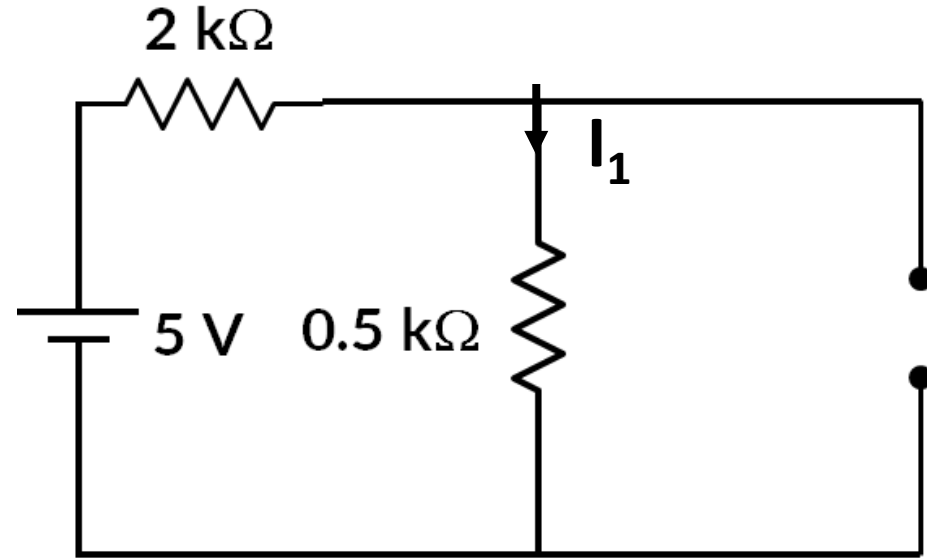
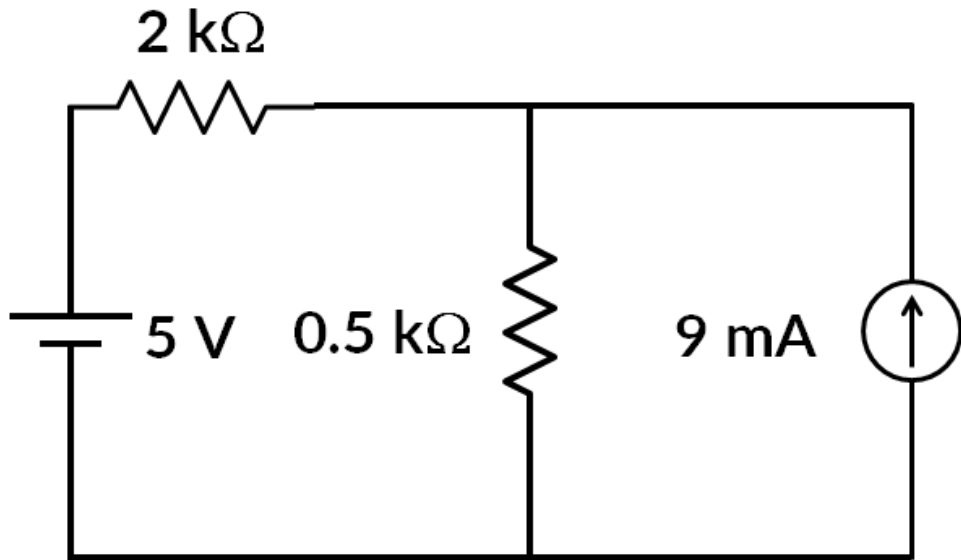

To Find the effect of 5 V source alone, replace the 9 mA source with a open circuit

$$I_1 = \frac{5V}{2k\Omega + 0.5k\Omega} = 2mA$$

To Find the effect of 9 mA source alone, replace the 5 V source with a short circuit

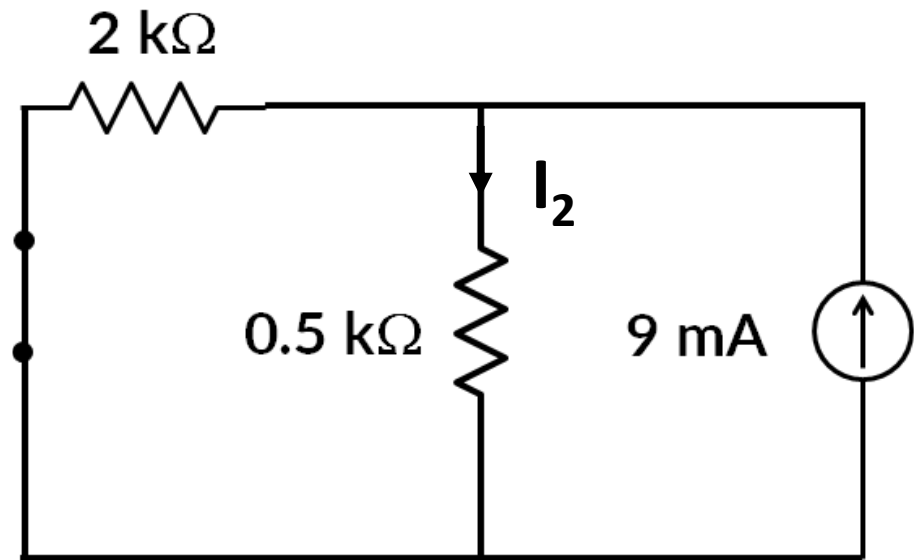
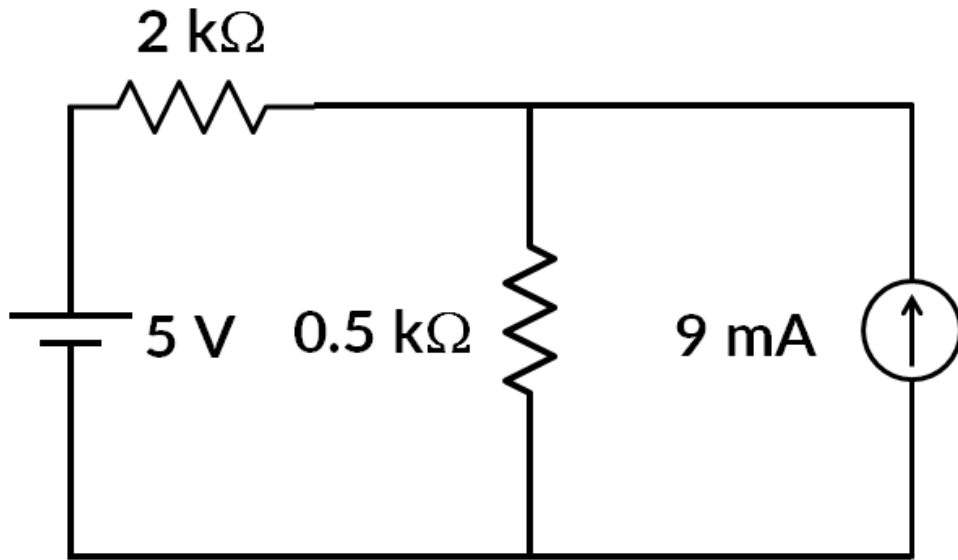

$$I_2 = 9 \text{ mA} \times \frac{2 \text{ k}\Omega}{2 \text{ k}\Omega + 0.5 \text{ k}\Omega} = 7.2 \text{ mA}$$

Total Current is given by $I = I_1 + I_2 = 2 \text{ mA} + 7.2 \text{ mA} = \mathbf{9.2 \text{ mA}}$

Maximum Power Transfer Theorem

- In all practical cases, energy sources have non-zero internal resistance. Thus, there are losses inherent in any real source.
- The aim of an energy source is to provide power to a load.
- Given a circuit with a known resistance, what is the resistance of the load that will result in the maximum power being delivered to the load?
- Consider the following circuit

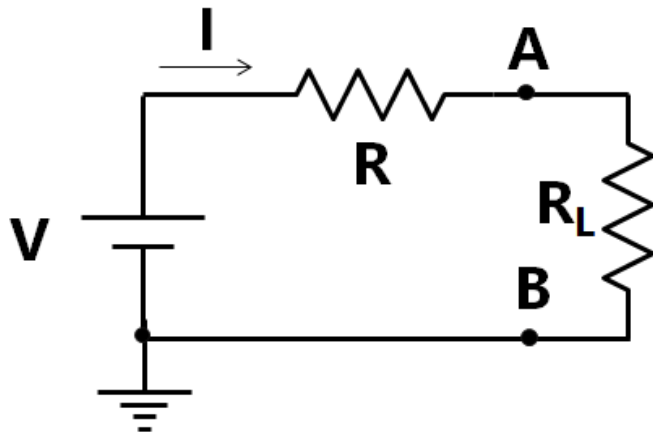

Maximum Power Transfer Theorem

The power delivered to the load (absorbed by R_L) is

$$P = I^2 R_L = \left(\frac{V}{R + R_L} \right)^2 R_L$$

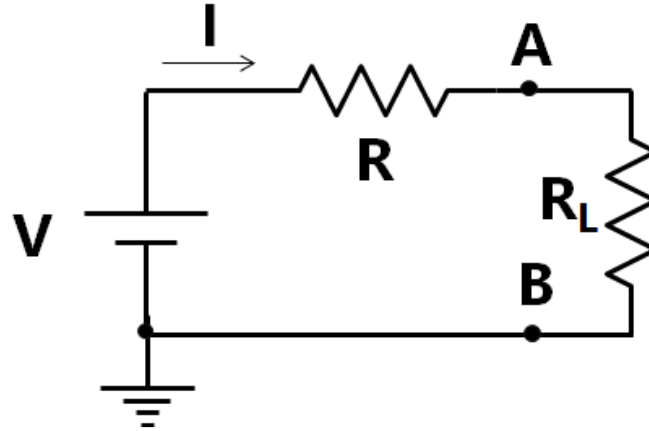

The power delivered to load is maximum when

$$\frac{\partial P}{\partial R_L} = 0$$

$$\frac{\partial P}{\partial R_L} = V^2 \left[\frac{1}{(R + R_L)^2} - 2R_L \frac{1}{(R + R_L)^3} \right] = 0$$

$$\frac{\partial P}{\partial R_L} = V^2 \left[\frac{1}{(R + R_L)^2} - 2R_L \frac{1}{(R + R_L)^3} \right] = 0$$

$$R + R_L = 2R_L$$

$$R_L = R$$

- Thus, maximum power transfer takes place when the resistance of the load equals is equal to the resistance of the circuit

$$P_{\max} = \left(\frac{V}{R + R_L} \right)^2 R_L \Big|_{R_L=R} = \frac{V^2}{4R}$$

- The power dissipated by R_L is 50% of the power produced by the ideal source when $R_L = R$.