

# Semiconductor Basics

# Classification of Materials : Electrical

- **Electrical Conductivity ( $\sigma$ ):** Ability to conduct charge through the material. Based on this three types of materials-
- **Conductors:** A material which has mobile charge carriers i.e. material capable of carrying charge (e.g. electrons, ions...)
  - e.g. : Metals, liquids with ions (e.g. water with common salt), Plasma
- **Insulators:** Materials with no or very less charge carriers
  - e.g. Quartz, all ionic and most of covalent solids, plastics
- **Semiconductors:** Materials with conductivity between conductors and insulators
  - e.g. : Silicon (Si), Germanium (Ge) etc.
- **Resistivity**  $\left(\rho = \frac{1}{\sigma}\right)$  is property of a material, while resistance is dependent on geometry.
- **Resistance**  $\left(R = \frac{\rho l}{A}\right)$  where  $l$  is length of the conductor and  $A$  is cross section through which carriers flow

# Classification of Materials : Electrical

Material	Example	Conductivity ( $\Omega^{-1}\text{cm}^{-1}$ )
Conductors	Aluminum	$10^{10}$
Semiconductors	Silicon	$10^{-1}$
Insulators	Silicon di oxide	$10^{-9}$

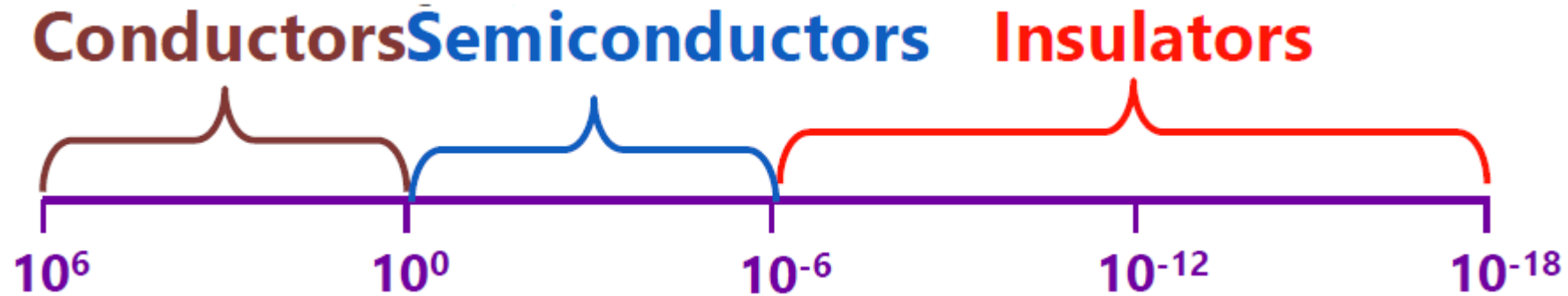

Electronic conductivities of materials, and different regions where different materials are characterized.

- **Band** is a region (energy) where electrons can exist
- **Valance band**: The highest energy band that is completely filled by electrons at 0K (where the valance electrons exist)
- **Conduction band**: The next higher energy band separated by a forbidden gap from the valance band (Where conduction electrons exist)
- **Energy gap (EG)**: is the difference between lowest the conduction band ( $E_C$ ) and highest of the valance band ( $E_V$ ). Energy gap of **Silicon is 1.1 eV** and **Germanium is 0.7 eV**.
- **Conductors**: If valance and conduction bands overlapping, then the material is called as a conductor.
- **Insulator**: If the energy gap is high ( $>3\text{eV}$ ), then the material is called as insulator
- **Semiconductor**: If the energy gap is less ( $\sim < 2\text{eV}$ ), the material is called as semiconductor

# Classification of Materials

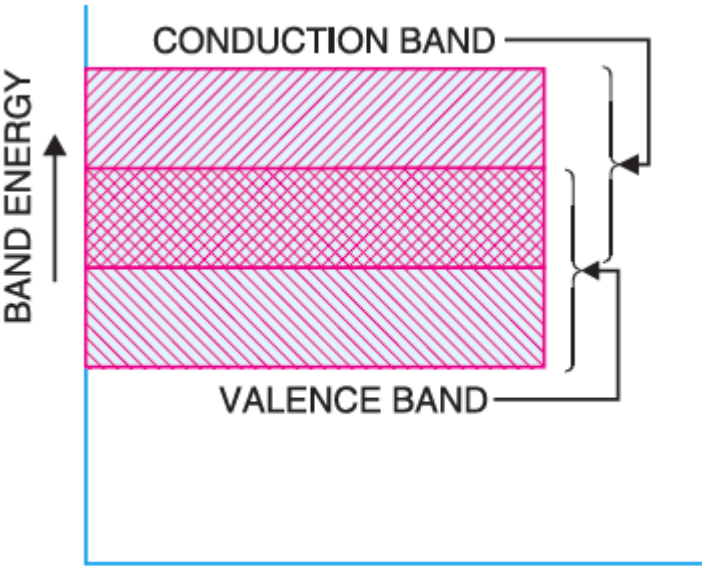

Conductors

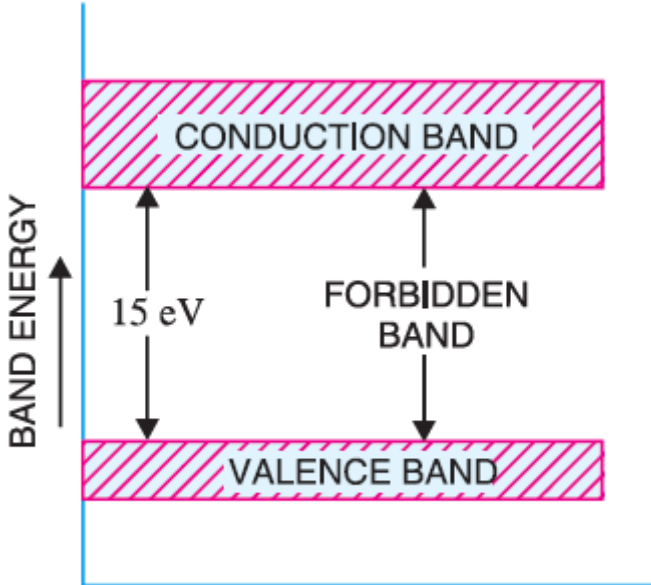

Insulators

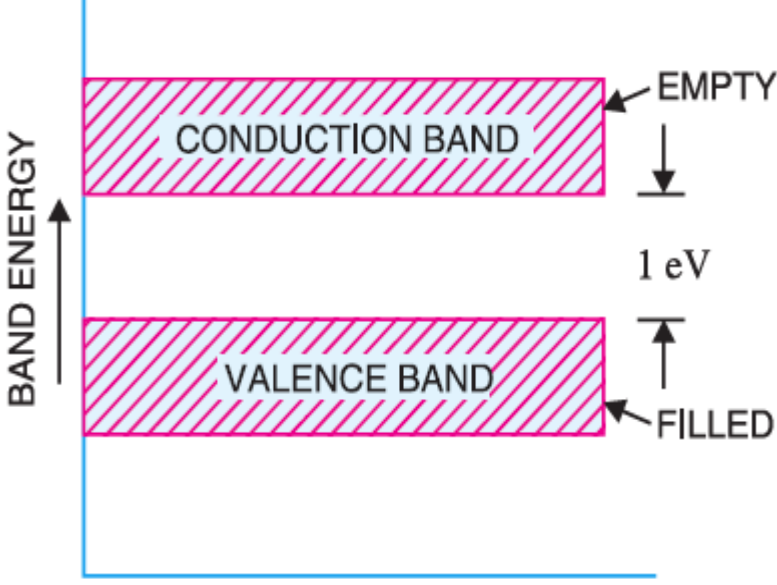

Semiconductors

# Classification of Semiconductors

- **Direct bandgap semiconductor:** The lowest point of the conduction band occurs at same value of crystal momentum ( $\vec{k}$ ) as the highest point of the valance band.
- **Indirect band gap semiconductor:** The lowest point of the conduction band does not occur at same value of crystal momentum ( $\vec{k}$ ) as the highest point of the valance band.
- The band gap is called "direct" if the momentum of electrons and holes is the same in both the conduction band and the valence band; an electron can directly emit a photon. In an "indirect" gap, a photon cannot be emitted because the electron must pass through an intermediate state and transfer momentum to the crystal lattice.

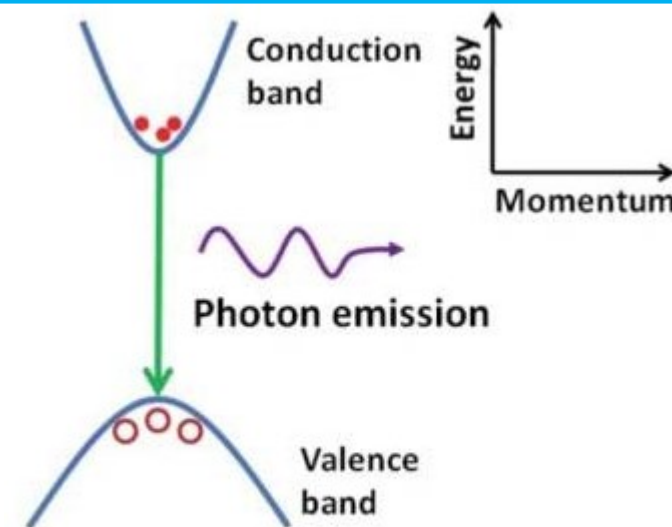

Direct bandgap

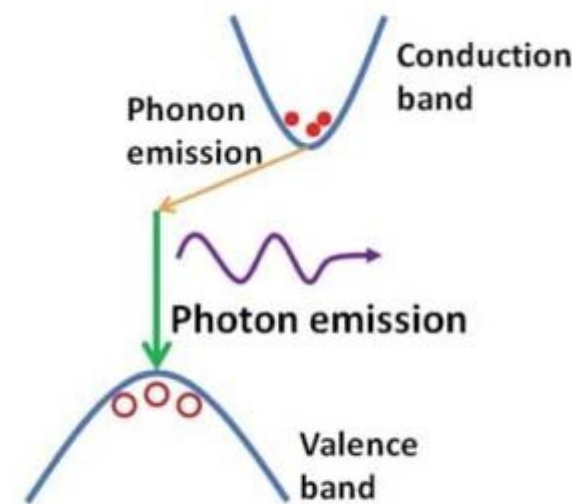

Indirect bandgap

# Semiconductors

- Silicon (Si)
  - most important semi conducting element
- Germanium (Ge)
  - has been the most frequently used element in earlier days.
- Gallium arsenide (Ga-As)
  - for high-frequency applications.
- Indium phosphide (InP)
  - for optoelectronics (LEDs).

If a semiconductor materials is formed by mixing more than one element, then it is called as a compound semiconductor.



Si electronic configuration

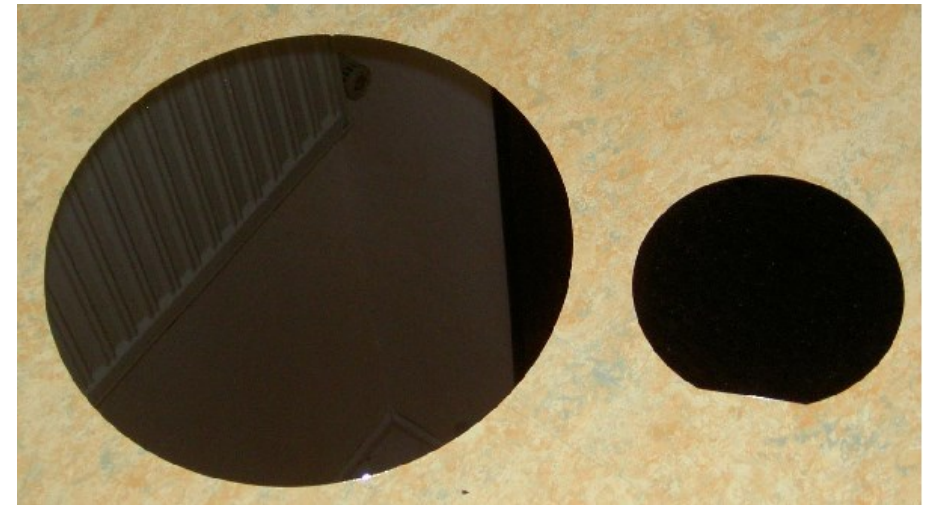

Silicon Wafer

# Intrinsic Semiconductors

- A defect free, pure semiconductor is called as intrinsic semiconductor
- Properties: No net charge
- Number of electrons ( $n$ ) is equal to number of holes ( $p$ )
- $n_i$ , called as intrinsic carrier concentration is a constant and equal to  $1.5 \times 10^{10} \text{ cm}^{-3}$ .

$$np = n_i^2$$

- The free electrons are produced due to the breaking up of some covalent bonds by thermal energy.
- At the same time, holes are created in the covalent bonds.
- Even at room temperature, hole-electron pairs are created.
- When electric field is applied across an intrinsic semiconductor, the current conduction takes place by two processes, namely ; by *free electrons* and *holes*

# Intrinsic Semiconductors

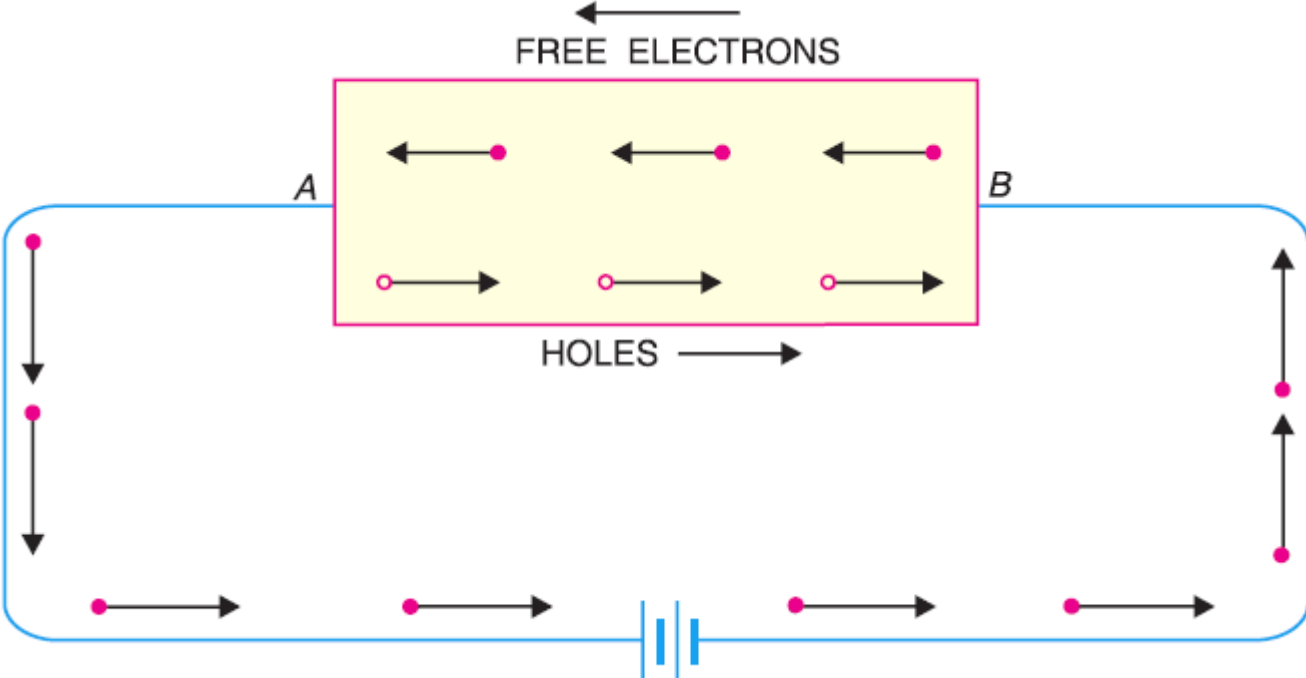

Current Conduction in an Intrinsic Semiconductor

# Intrinsic Semiconductors

- Band diagram is a plot of electron energy versus position in a semiconductor
- $E_C$  represents the minimum available energy state in conduction band
- $E_V$  represents the maximum available energy state in valence band
- There is no available energy levels between  $E_C$  and  $E_V$
- The mid gap: 
$$E_C - E_i = \frac{E_G}{2} = E_i - E_V$$
- $E_i$  is called intrinsic fermi level and at  $T=0$  K, positioned at  $\frac{E_G}{2}$
- number of holes in valence band = number of electrons in conduction band

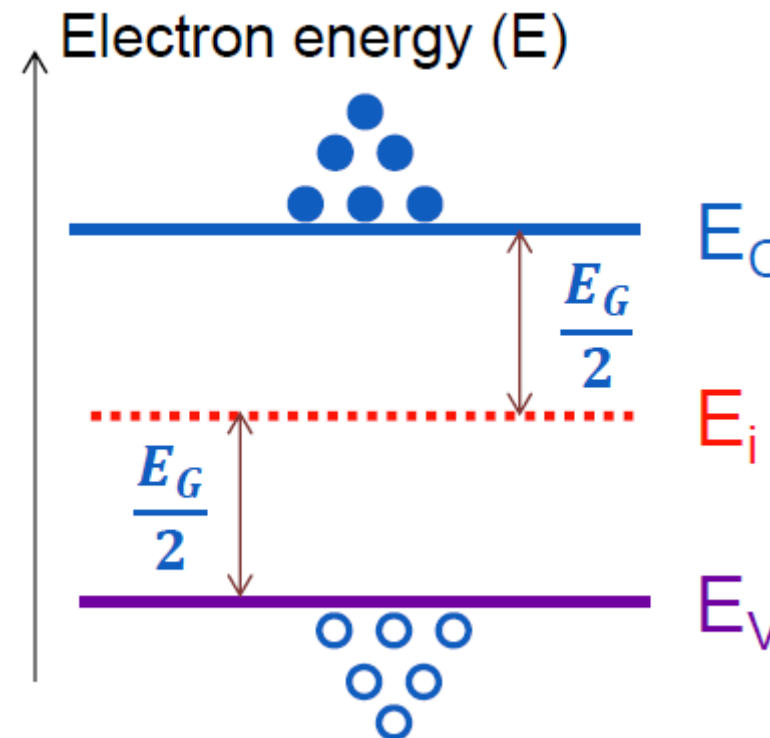

# Extrinsic Semiconductors

- Impure semiconductor → Doping to increase performance
- Need doping to make semiconductor devices work
- Two types of dopants → Acceptor and Donor

## Extrinsic Semiconductors: n-type

- A dopant atom which donates an electron to lattice is called as donor atom or donor
- Extra electron in the lattice doesn't mean electrically negative silicon
- Extra electron is compensated by positively atom core of donor atom, also called as ionized donor atom
- As the electron generated is free and doesn't require corresponding hole, **electron** concentration is more
- The semiconductor is called **n-type** semiconductor
- Pentavalent atoms e.g., Phosphorous, Arsenic are important n-type dopants

## Extrinsic Semiconductors: n-type

- Inject Arsenic or phosphorous into the crystal with an implant step.
- Arsenic is Group 5 element with 5 electrons in its outer shell, (one more than germanium or silicon).
- This introduces extra electrons into the lattice which can be released through the application of heat and so produces an electron current
- The result here is an n-type semiconductor (n for negative current carrier)

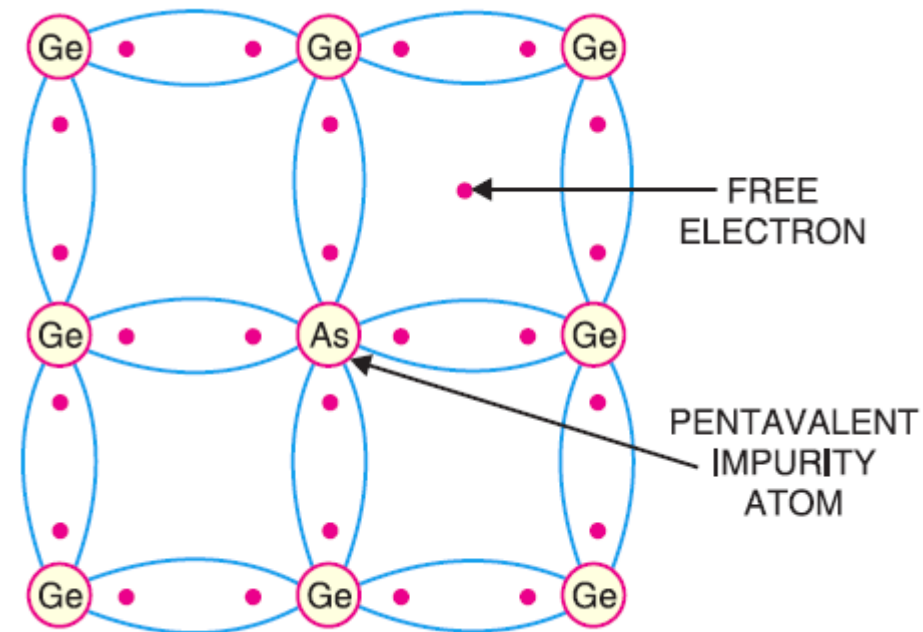

## Extrinsic Semiconductors: n-type

- Donor atom introduces a donor level which is very close to (just below the) conduction band
- An imaginary energy level called as extrinsic Fermi level is introduced, positioned between  $E_C$  and  $E_i$ .
- n-type silicon crystal contains electrons and holes which can move and positively charged immobile dopant atoms that cannot move as electrons
- The current flowing out of this material is primarily electron current
- **Electrons** are called as **majority carriers** and **Holes** are called as **minority carriers**
- $n \gg p$       $np = n_i^2$       $n = n_i e^{\frac{(E_F - E_i)}{kT}}$

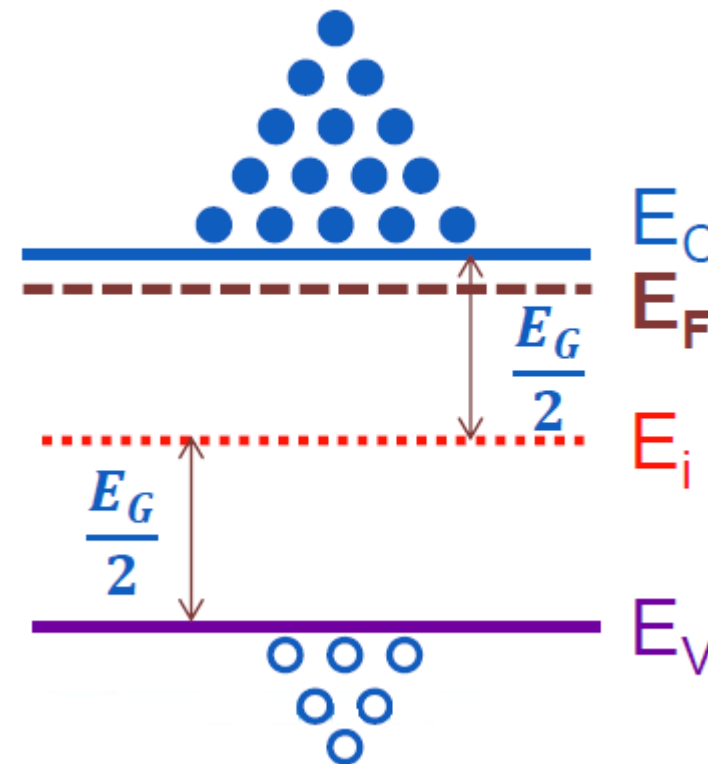

## Extrinsic Semiconductors: p-type

- A dopant atom which accepts an electron from lattice is called as acceptor atom or acceptor
- Electrons jump from the valance band to acceptor level thus creating large number of holes
- Generation of extra holes doesn't mean electrically positive silicon
- Extra hole is compensated by negative atomic core of acceptor atom
- As the hole generated is free and no corresponding electron is required, semiconductor has more holes than electrons
- The semiconductor is called p-type semiconductor
- Trivalent atoms, Boron, Indium are important p-type dopants

# Extrinsic Semiconductors: p-type

- Inject Boron or Gallium into the crystal with an implant step.
- Boron is Group 3 element having 3 electrons in its outer shell (one less than silicon)
- This introduces holes into the lattice which can be made mobile by applying heat. This gives us a hole current
- The result is a p-type semiconductor (p for positive current carrier)

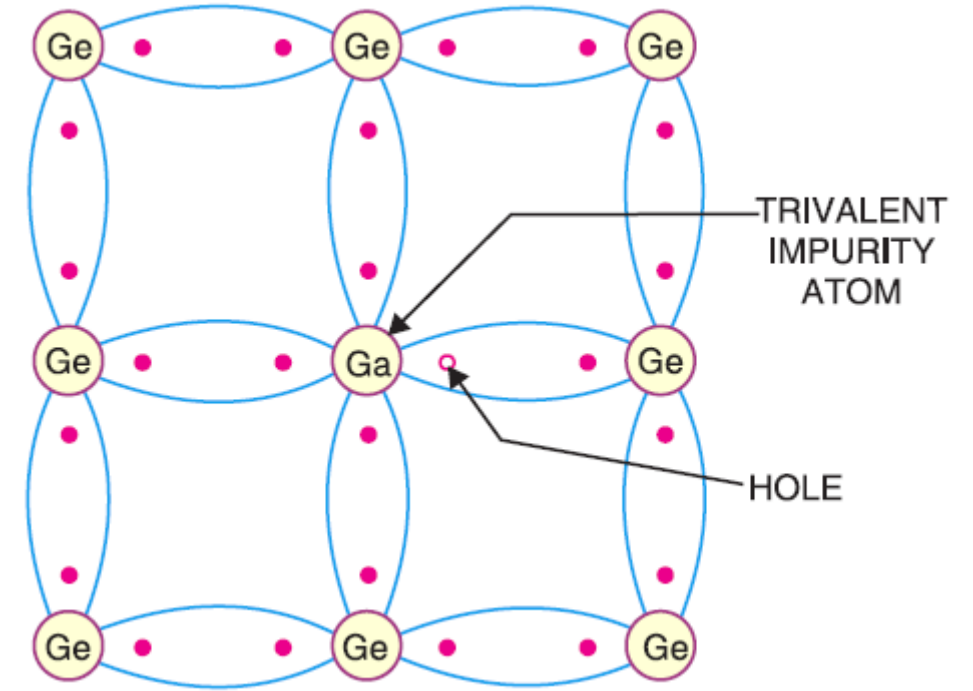

## Extrinsic Semiconductors: p-type

- Acceptor atom introduces an acceptor level which is very close to (just above the) valence band
- An imaginary energy level called as extrinsic Fermi level is introduced and positioned between  $E_i$  and  $E_v$
- p-type silicon crystal contains holes and electrons which can move and negatively charged immobile dopant atoms that cannot move as holes,
- The current flowing out of this material is primarily hole current
- Holes are called as majority carriers
- Electrons are called as minority carriers

- $p \gg n$        $p = p_i e^{\frac{(E_i - E_F)}{kT}}$

