

Department of ECE, Bennett University

CSET102: Introduction to Electrical and Electronics Engineering

Tutorial Sheet-1

1. For the circuits shown in fig. 1 to fig. 6, find the equivalent resistance between nodes A and B. What is the current through the circuit and power delivered by the voltage source?

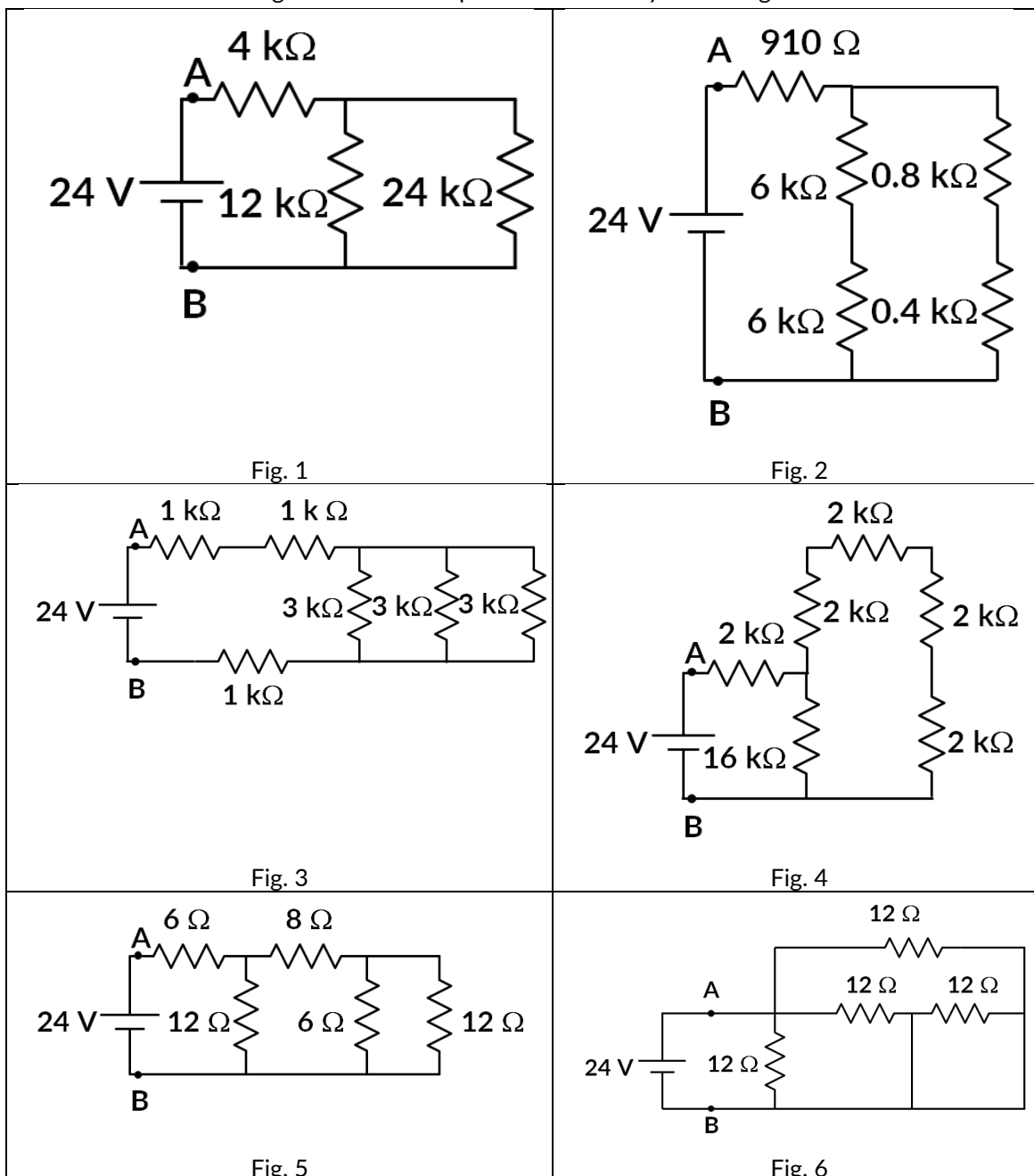

2. For the circuits shown in fig. 7 to fig. 9, find the equivalent resistance between nodes A and B. For the circuits in fig. 7 to fig. 9, each resistor has a resistance of R .

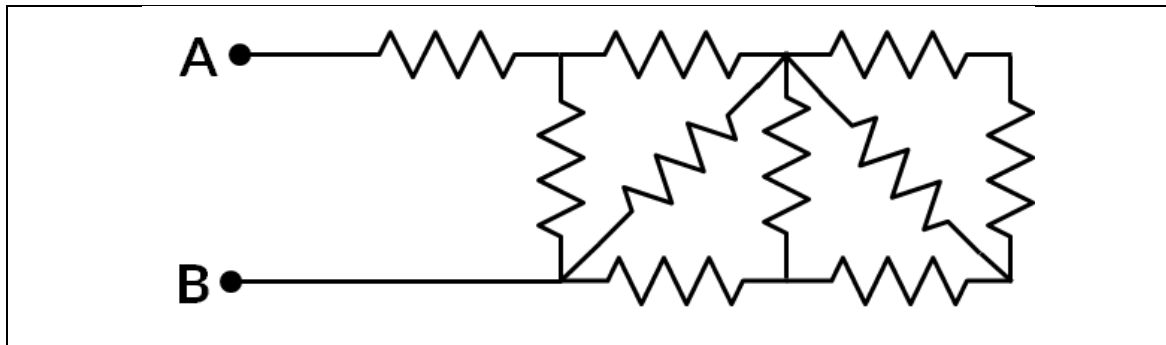

Fig. 7

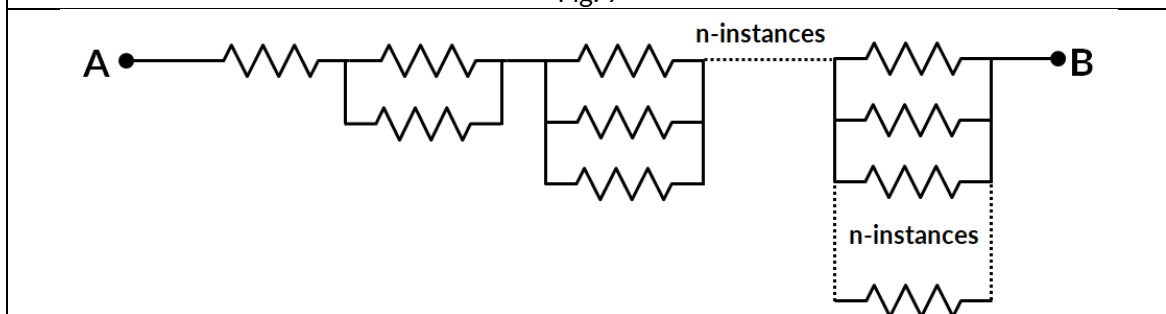

Fig. 8

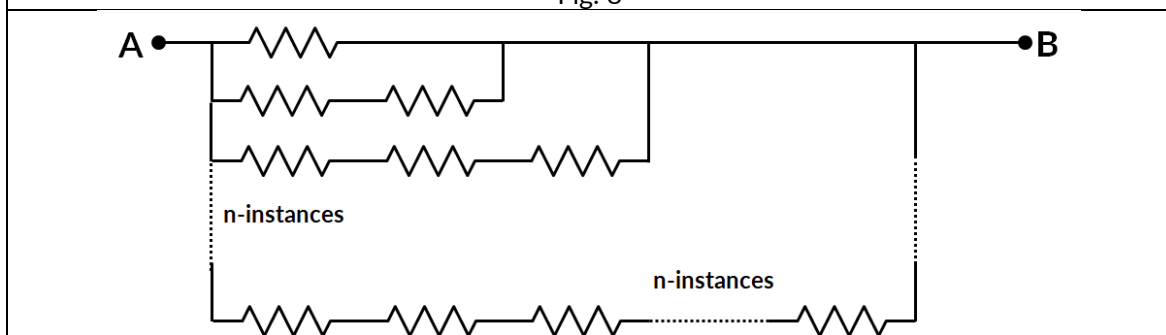
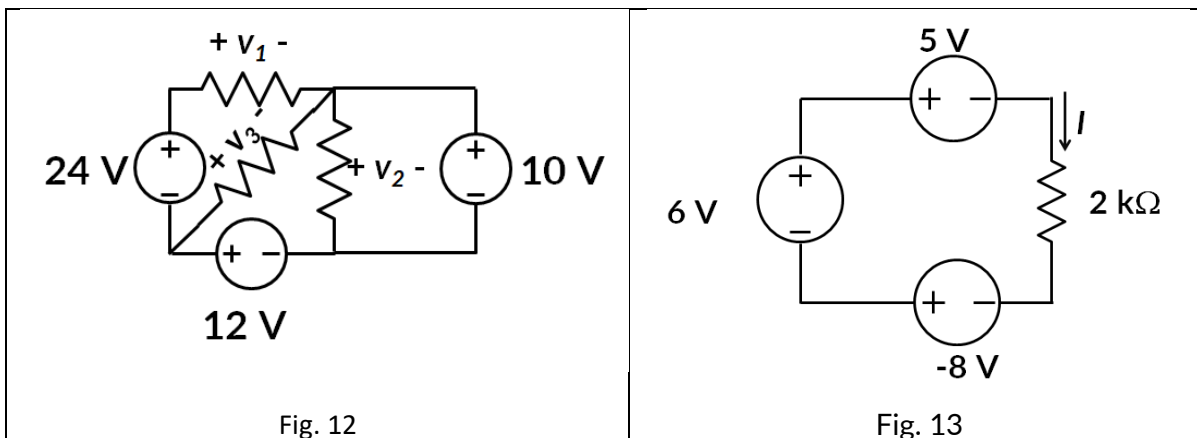
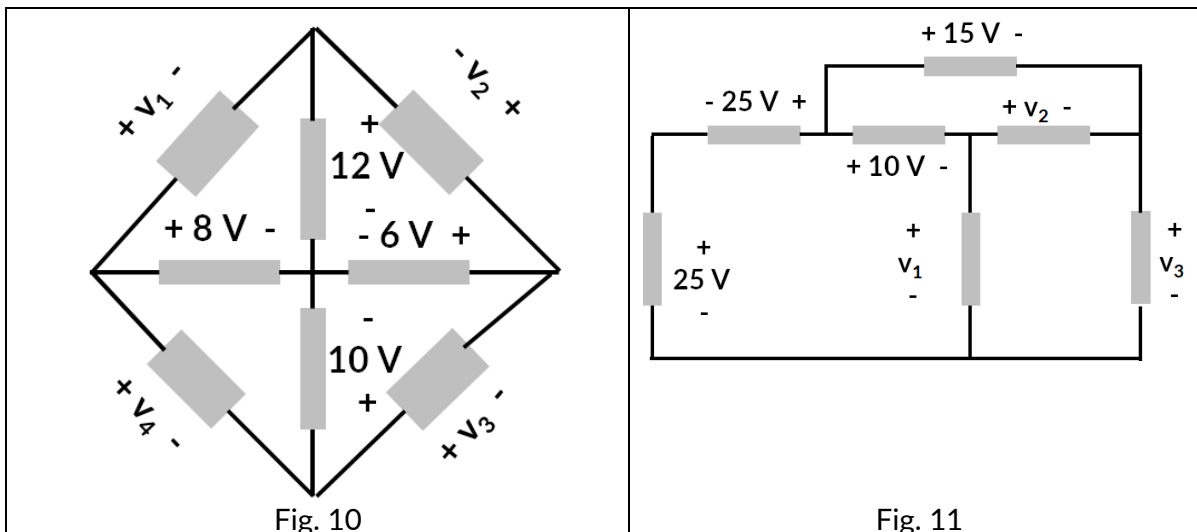

Fig. 9

3. For the circuit shown in fig. 10, determine V_1 through V_4 .
4. For the circuit shown in fig. 11, determine V_1 , V_2 and V_3 .
5. For the circuit shown in fig. 12, determine V_1 , V_2 and V_3 .
6. Find the current I and the power absorbed or supplied by each element in the circuit shown in fig. 13.



----- END OF QUESTIONS -----

Answers:

Question 1:

	V	R	I	P
Fig. 1	24	12 k Ω	2 mA	48 mW
Fig. 2	24	2 k Ω	12 mA	288 mW
Fig. 3	24	4 k Ω	6 mA	144 mW
Fig. 4	24	7.3 k Ω	3.3 mA	79.2 mW
Fig. 5	24	12 Ω	2 A	48 W
Fig. 6	24	4 Ω	6 A	144 W

Question 2:

Fig. 7: $\frac{89}{55} RR$

Fig 8: ∞

Fig. 9: 0

Question 3:

$$v_1 = -4 \text{ V}, v_2 = -6 \text{ V}, v_3 = 4 \text{ V}, v_4 = -2 \text{ V}$$

Question 4:

$$v_1 = 40 \text{ V}, v_2 = 5 \text{ V}, v_3 = 35 \text{ V}$$

Question 5:

$$v_1 = 26 \text{ V}, v_2 = 10 \text{ V}, v_3 = 2 \text{ V}$$

Question 6:

$$I = -3.5 \text{ mA}$$