

Department of ECE, Bennett University

CSET102: Introduction to Electrical and Electronics Engineering

Tutorial Sheet-4

Topics Covered: Source Transformation/Source conversion

1. For the circuit shown in Fig. 1, by converting the current source into voltage source, find the current through $91\ \Omega$ resistor.

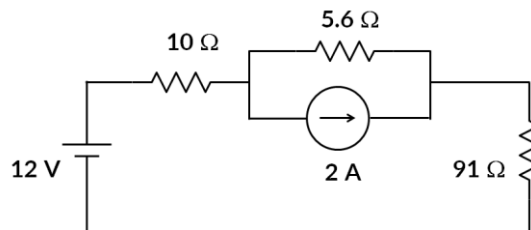

Fig. 1

2. For the network shown in fig. 2, by replacing all the current sources with a single current source, find the source voltage V_s .

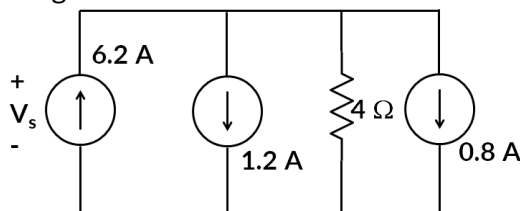

Fig. 2

3. For the network shown in fig. 3, find the voltage V_s and current through $4\ \Omega$ resistor.

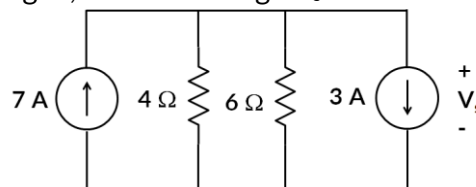

Fig. 3

4. For the circuit shown in fig. 4, determine the current through $12\ \Omega$ resistor by changing the voltage sources into current sources.

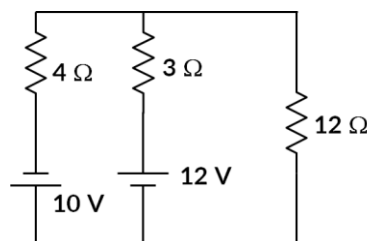

Fig. 4

5. In the circuit shown in fig. 5, find the voltage V_{ab} and current through $6\ \Omega$ resistance.

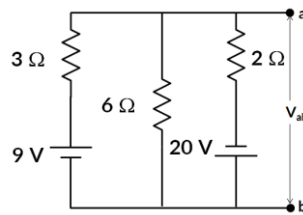

Fig. 5

6. For the circuit shown in fig. 6, find the voltage V_s and current through 12 V source.

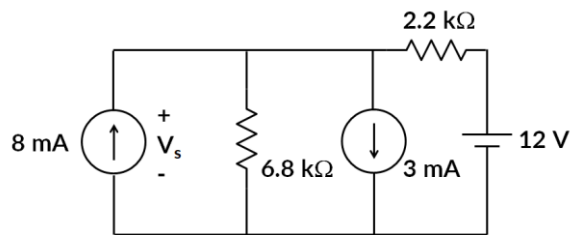

Fig. 6

Topics Covered: Superposition Theorem (Principle of Superposition)

7. Using superposition theorem, find the current flowing through $12\ \Omega$ resistance in fig. 7.

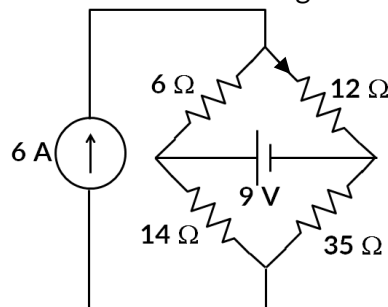

Fig. 7

8. Using superposition principle (superposition theorem), in the circuit shown in fig. 8, find the current flowing through $2\ \Omega$ resistance.

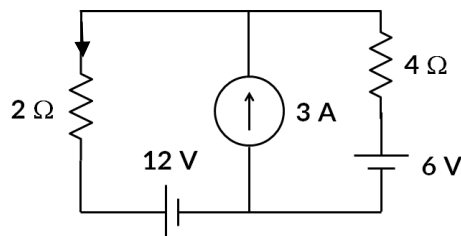

Fig. 8

9. Using superposition theorem, for the circuit shown in fig. 9, determine the voltage across the $4.7\ \Omega$ resistor and power delivered to the resistor. Find the power delivered to $4.7\ \Omega$

resistor solely by voltage source and solely by current source. What are your observations and reasons for discrepancies if any.

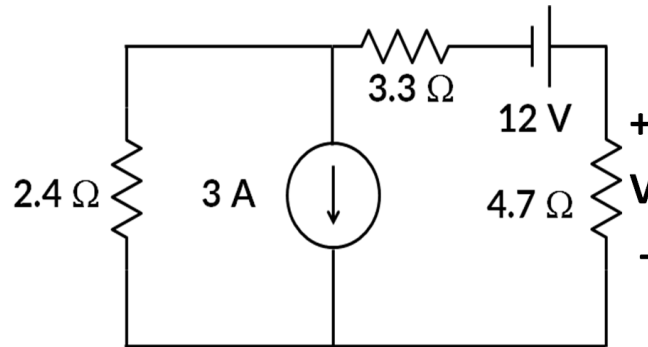

Fig. 9

10. Using superposition theorem, find the current through 56Ω resistor for the circuit in fig. 10.

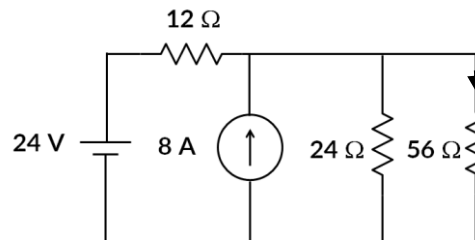

Fig. 10

11. Using superposition theorem, for the 24 V source shown in fig. 11, find the current through and power consumed or delivered by the 24 V source.

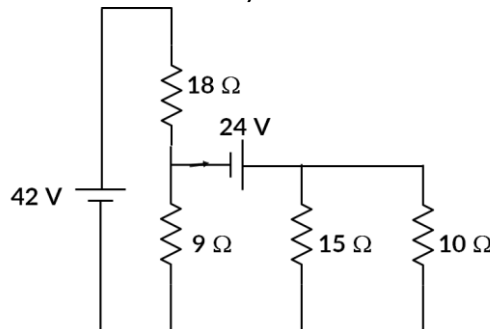

Fig. 11

Answers:**Source Transformation/ Source Conversion**

- 1) 218 mA
- 2) 16.8 V
- 3) 9.6 V, 2.4 A
- 4) 0.19 A
- 5) -7 V, -1.17 A
- 6) 17.35 V, 2.43 A

Superposition Theorem

- 7) $I(6 \text{ mA}) = 2 \text{ A}$, $I(9 \text{ V}) = 0.5 \text{ A}$, $I = 2.5 \text{ mA}$
- 8) $I(12 \text{ V}) = -2 \text{ A}$, $I(6 \text{ V}) = 1 \text{ A}$, $I(3 \text{ A}) = 2 \text{ A}$, $I = 1 \text{ A}$
- 9) $V(3 \text{ A}) = -3.25 \text{ V}$, $P(3 \text{ A}) = 2.24 \text{ W}$; $V(12 \text{ V}) = 5.53 \text{ V}$, $P(12 \text{ V}) = 6.51 \text{ W}$, $P = 1.106 \text{ W}$
($P \neq P_1 + P_2$ Reason?)
- 10) $I(24 \text{ V}) = 0.25 \text{ A}$, $I(8 \text{ A}) = 1 \text{ A}$, $I = 1.25 \text{ A}$
- 11) $I(42 \text{ V}) = 1.17 \text{ A}$, $I(24 \text{ V}) = 2 \text{ A}$, $I = 3.17 \text{ A}$, $P = 76.08 \text{ W}$