

Department of ECE, Bennett University
CSET102: Introduction to Electrical and Electronics Engineering
Tutorial Sheet-8

Topics Covered: PN Junction diode and Diode circuits

If not mentioned, assume non-ideality factor (η) as 1, reverse saturation current I_0 as 5 nA.

1. A PN junction diode having reverse saturation current of 10^{-11} A is forward biased so that the current through the diode is $150 \mu\text{A}$. Find the diode voltage.
2. At what reverse bias voltage does the reverse bias current in a PN Junction reaches 90% of its reverse saturation current?
3. What is the ratio of the current for a forward-bias voltage of 0.2 V to the current for a reverse-bias voltage of 0.2 V?
4. For the diode circuit shown in Fig. 1, $V_s = 2$ V. The silicon diode has a reverse saturation current of 1 nA at 300 K. Given that $V = 0.7$ V. Find
i) R_2 when $R_1 = 1$ k Ω and ii) R_1 when $R_2 = 1$ k Ω

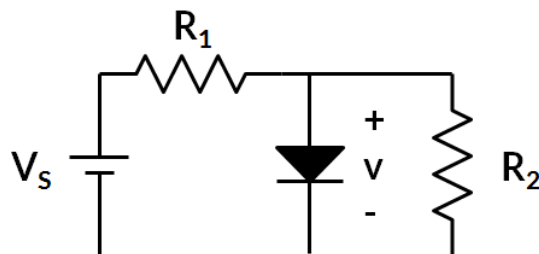

Fig. 1.

5. The diode circuit shown in Fig. 2, D_1 and D_2 are silicon diodes having saturation currents of 5 nA and 10 nA, respectively, at 300 K. Given that both the diodes are forward biased. Find the values of R for which the current is 15 mA.

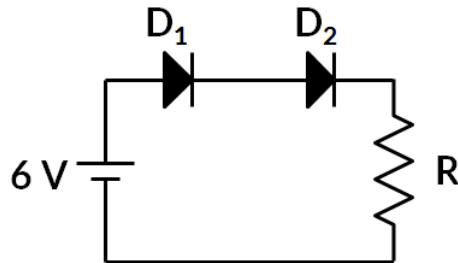

Fig. 2.

6. For the ideal diode circuit shown in Fig. 3, let $R_f = 1\text{ k}\Omega$ and $R = 9\text{ k}\Omega$. Find the output voltage V_0 when
- $V_1 = V_2 = 0\text{ V}$
 - $V_1 = 10\text{ V}, V_2 = 0\text{ V}$
 - $V_1 = V_2 = 10\text{ V}$

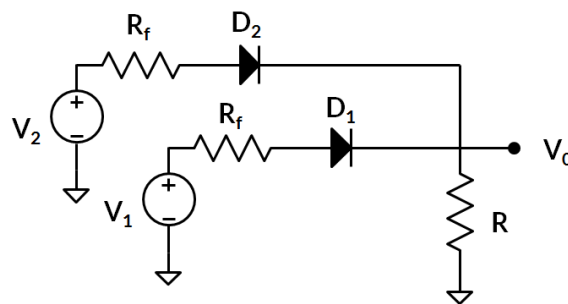

Fig. 3

7. Assume that each diode in the circuit shown in fig. 4 has a cut-in voltage 0.65 V.

i) If the input voltage is $V_1 = 5\text{ V}$, determine the value of R_1 such that I_{D1} is one-half of I_{D2} . What are the values of I_{D1} and I_{D2} ?

ii) If $V_1 = 8\text{ V}$ and $R_1 = 2\text{ k}\Omega$, determine I_{D1} and I_{D2} .

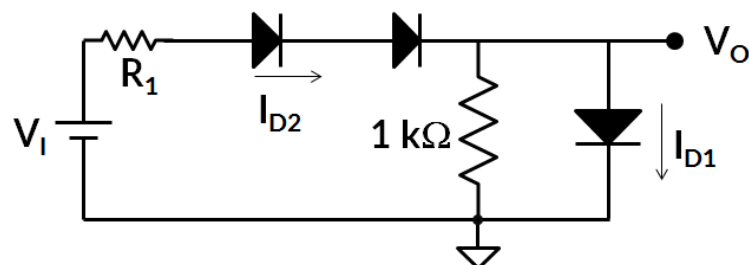

Fig. 4

8. In the circuit shown in fig. 5, find the diode voltage V_D and the supply voltage V such that the current $I_D = 0.4 \text{ mA}$. Assume cut-in voltage is 0.7V . What is the power dissipated by the diode?

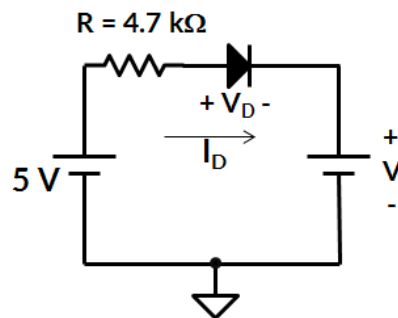

Fig. 5

Topics Covered: Applications of Diodes

Half wave rectification:

9. Assume a sinusoidal waveform with an amplitude of 10 V and 60 Hz is applied to the circuit shown in fig. 6. Draw the output waveform across the resistor and diode by assuming the diode is (i) ideal (ii) non-ideal.

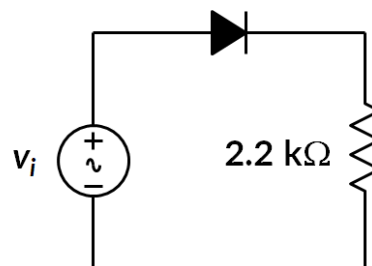

Fig. 6

10. A full-wave bridge rectifier with a 200 V peak-to-peak input has a load resistance of $3.3 \text{ k}\Omega$. Draw the output voltage waveform as seen across the load.

----- END OF QUESTIONS -----

Answers:

- 1) 0.43 V
- 2) -0.06 V
- 3) 2193.4
- 4) i) $R_2 = 538 \Omega$, ii) $R_1 = 1.86 \text{ k}\Omega$
- 5) $R = 350 \Omega$
- 6) i) $V_O = 0 \text{ V}$ ii) $V_O = 8.46 \text{ V}$ iii) $V_O = 8.91 \text{ V}$
- 7) i) $I_{D1} = 0.65 \text{ mA}$, $I_{D2} = 1.3 \text{ mA}$, $R_1 = 2.35 \text{ k}\Omega$ ii) $I_{D1} = 2.375 \text{ mA}$, $I_{D2} = 3.025 \text{ mA}$
- 8) $V = 2.42 \text{ V}$, $P = 0.28 \text{ mW}$